

# VISIO 300 V3

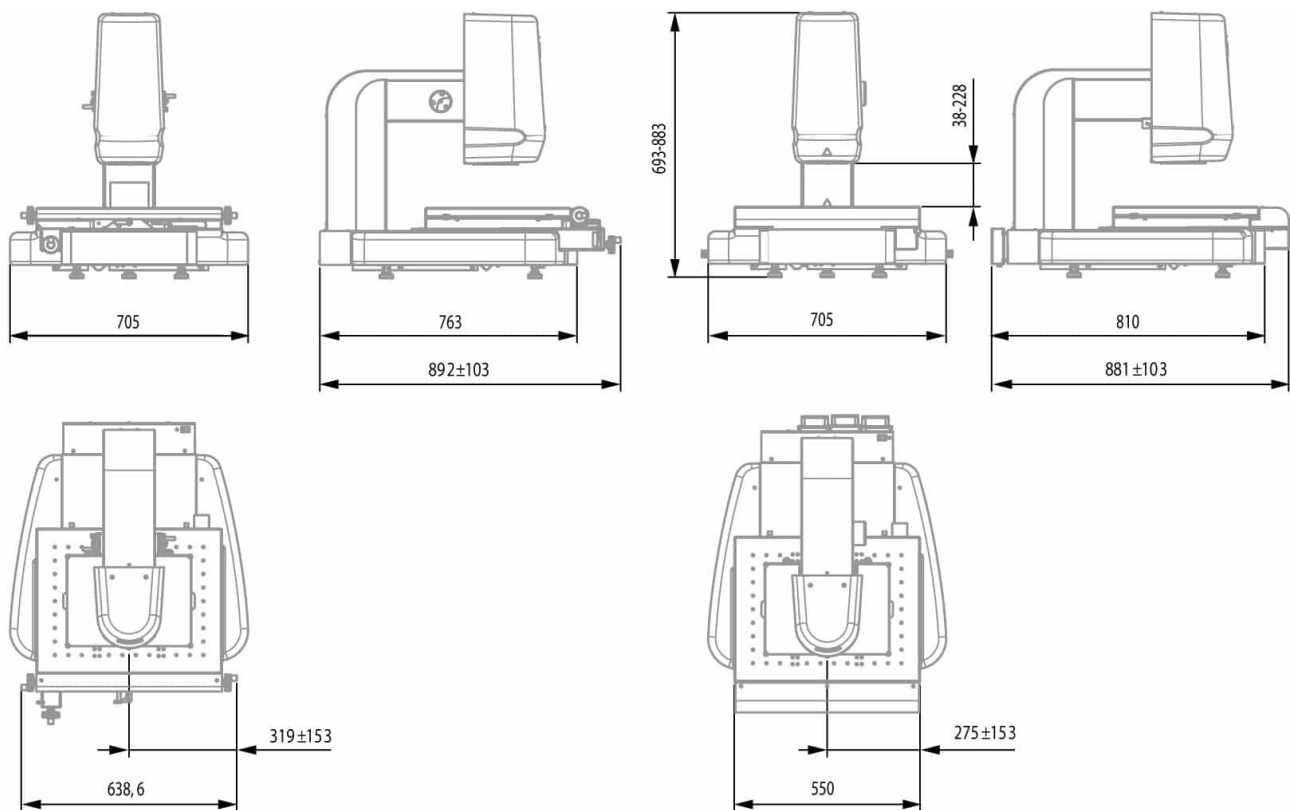

	<b>902-2310</b>
EAN	7640125714883
Measuring volume (mm)	300x200x150
X, Y Accuracy (E1, X, Y) (µm)	$1.9 + 4L/1000$ (L = mm) <sup>1/3</sup>
XY Accuracy (E2, XY) (µm)	$2.4 + 4L/1000$ (L = mm) <sup>1/3</sup>
Z Accuracy (E1, Z) <sup>2</sup> (µm)	$2.9 + 10L/1000$ (L = mm)
Resolution (mm)	0.001
Max. load capacity (kg)	20
Magnification (screen 23.8")	24x – 144x (12x – 288x with additional lenses)
Zoom	Motorised 6x
Weight	170
International standards	EN61000-6-2, EN61000-6-4, EN61326-1, EN12100-1, EN12100-2

<sup>1</sup> m ≤ 5 kg

<sup>2</sup> mechanical accuracy

<sup>3</sup> at glass plate level