



Special caliper

S_Cal EVO

DESCRIPTION

SMART EXTERNAL GROOVE

- High-quality, ergonomic caliper with integrated Bluetooth® system
- Model for the measurement of external grooves from 2.6 mm wide
- 3.5 mm thick hardened and ground stainless steel frame
- New extra-large display unit with 11.5 mm high digits
- Convenient push button for sending data that can also be programmed with another function
- Memorising the home position even when the instrument is switched off
- Measuring range 150 mm with rectangular depth rod
- Protection class IP67
- Wheel available as an option

C

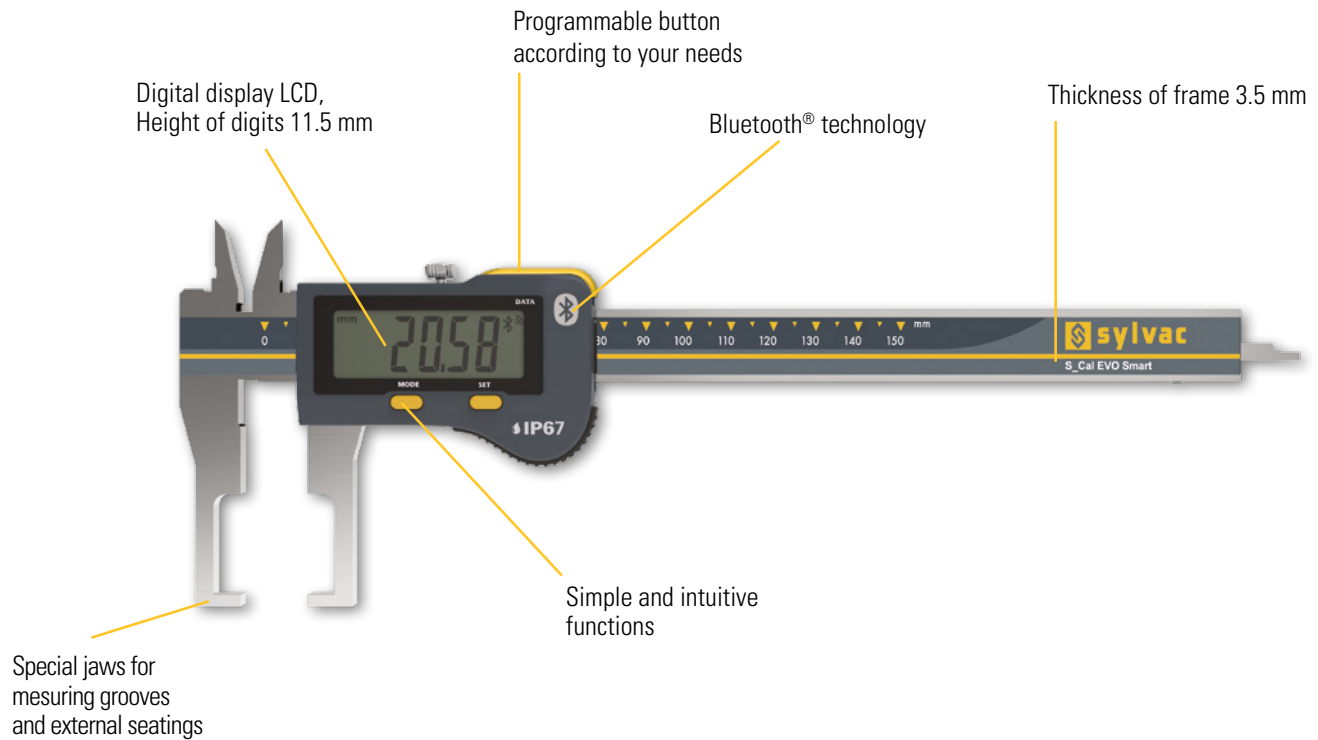

ISO 13385-1



* SIS description on page 5

For measuring grooves and external seatings



Special caliper

S_Cal EVO

DIMENSIONAL DRAWING

SMART EXTERNAL GROOVE

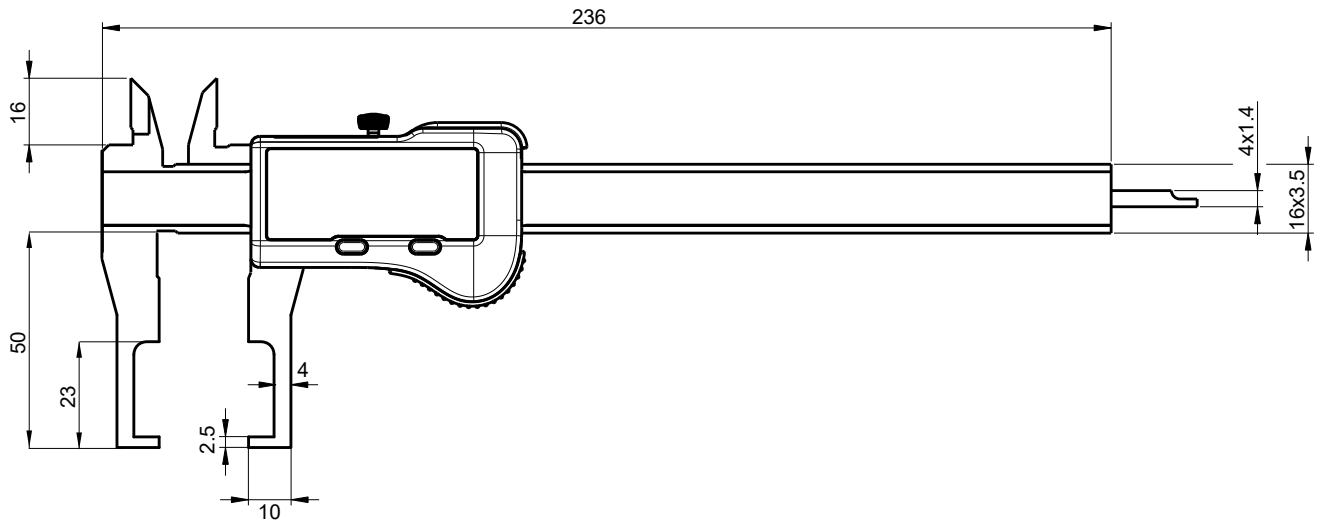

TECHNICAL SPECIFICATIONS

		810-1602
Measuring range	mm	150
Max. Error G - external measurements	µm	20 ¹⁾
Max. Error - internal measurements	µm	20-30 ²⁾
Depth rod	mm	— 4 x 1.4
Protection rating according to IEC 60529		IP67
Output data		Bluetooth® wireless technology*
Functions		Zero setting, Preset (max 999.99), mm/inch, Hold, Data
Smart Inductive Sensor		●

¹⁾ 0-150 mm : 20 µm / ISO13385-1

²⁾ Ø4-25 : 20 µm / ISO13385-1
Ø26-150 : 30 µm / ISO13385-1

*** Up to 8 instruments connected per dongle #981-7100**